

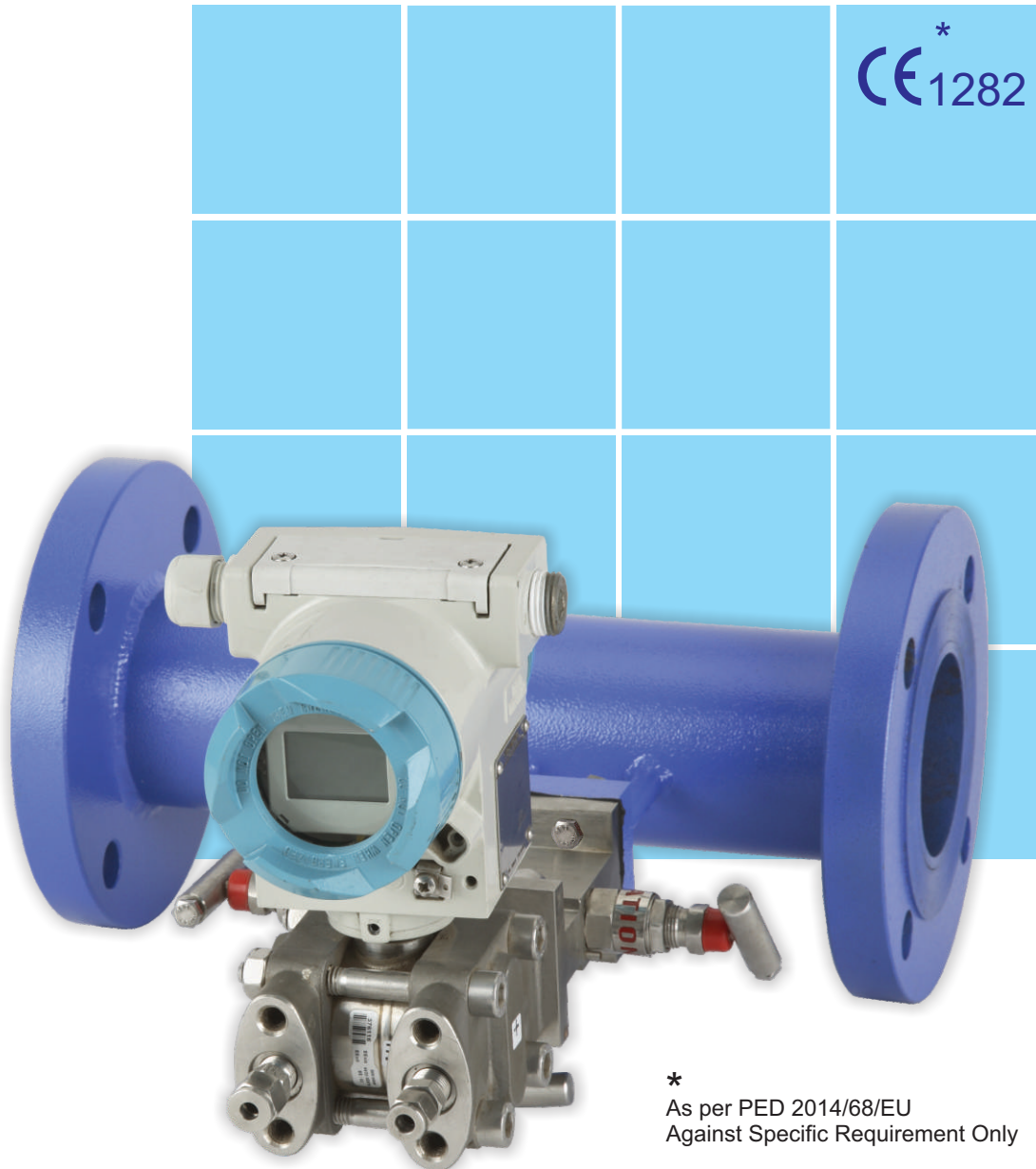

EUREKONE FLOWMETER

A perfect solution for industry's difficult flow measurement problems



*
As per PED 2014/68/EU
Against Specific Requirement Only

**EUREKA
INDUSTRIAL
EQUIPMENTS
PVT. LTD.**

REGD. & SALES OFFICE : 17-20, 1st Floor, Royal Chambers, Paud Road, Pune - 411 038, Maharashtra, India.

■ Tel: 0091-20-25443079 ■ sales@eurekaflow.com

FACTORY : 501, 'J' Block, M.I.D.C., Pimpri, Pune - 411018.

■ Email: works@eurekaflow.com

MUMBAI OFFICE : Office No.116, Growmore Tower, 1stFloor, Plot No.5, Sector No.2, Kharghar, Navi Mumbai - 410 210 ■ Mobile: 9322598274

The EUREKONE FLOWMETER is a new differential pressure flowmeter device that accurately measures flow of various fluids over wider flow range than any other conventional differential pressure flowmeter such as venturies, orifice plates etc. The basic principle is Bernoulli's theorem for the conservation of energy in fluid flow through a pipe. The divergent shape of the cone sensor centered in the line, reshapes the velocity profile to create an improved profile. The configuration of a typical EUREKONE FLOWMETER is showing fig. A/B.

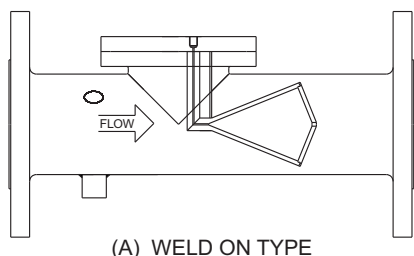

(A) WELD ON TYPE

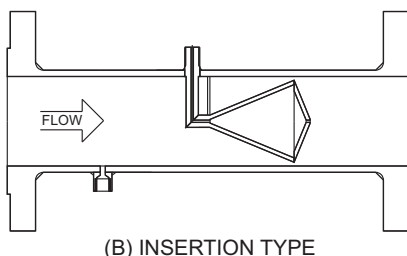

(B) INSERTION TYPE

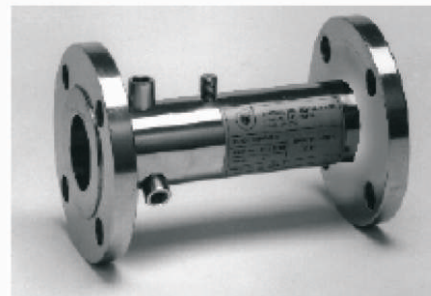

The pressure difference between the static line pressure and the lower pressure created just after the cone sensor can be measured via two pressure sensing taps. One placed slightly upstream of the cone sensor & the other in the downstream face of the cone sensor itself and is related to flowrate through the meter.

ACCURACY

The EUREKONE FLOWMETER is able to operate accurately over wider flow ranges than any other differential pressure flow meter. An accuracy of better than $\pm 1\%$ of actual flow is achievable to the majority of the applications.

REPEATABILITY

The EUREKONE FLOWMETER exhibits a repeatability of better than $\pm 0.1\%$ the high repeatability creates a very steady output signal. This is because the shape of the cone sensor is specifically designed to dampen the amplitude of the oscillation for the measured pressure field.

RANGEABILITY

The EUREKONE FLOWMETER is more rangeable than any other differential pressure devices because it reshapes and flattens the fluid velocity profile (fig.2) flow rate turndown of upto 10 to 1 are easily measured.

LONG TERM PERFORMANCE

The EUREKONE FLOWMETER has no moving parts like bearings & gears, so problems which are typical to rotary meters are eliminated. As the cone sensor has divergent shape, the flow is directed away from the critical edge & the edge is not damaged by foreign solid particles present in the stream. There are no stagnant fluid areas for gaseous build up or solids entrapment as it is in the orifice plate. The performance is therefore unaffected by these common problems.

SIGNAL STABILITY

The output of the D. P. Transmitter when connected across **EUREKONE** is highly stable as compared to output of D. P. Transmitter when connected across orifice. Due to special design of cone sensor, the flowmeter does not allow debris, condensation or particles from the fluid to accumulate.

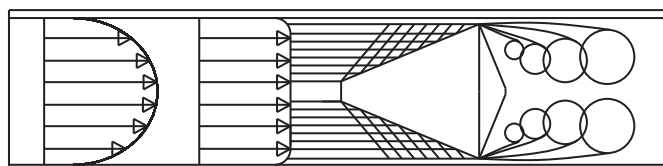

FIG.2 VELOCITY PROFILE REDISTRIBUTION

SECONDARY INSTRUMENTATION

The EUREKONE FLOWMETER works with any standard Differential Pressure Gauge, D.P. Transmitters, Manometers, etc. The EUREKONE FLOWMETER can be incorporated into an existing system without having to invest in new instrumentation. The EUREKONE FLOWMETER Combined with D. P. Transmitter and flow computer forms a complete system to meet stringent applications as shown in FIG.3 & 4

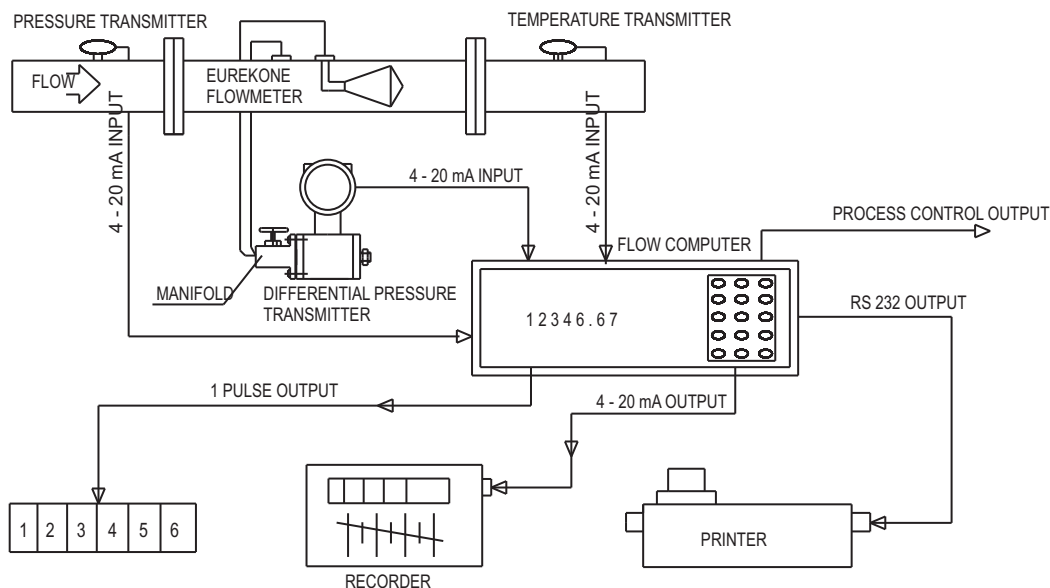

FIG. 3 - TYPICAL SECONDARY INSTRUMENTATION SYSTEM

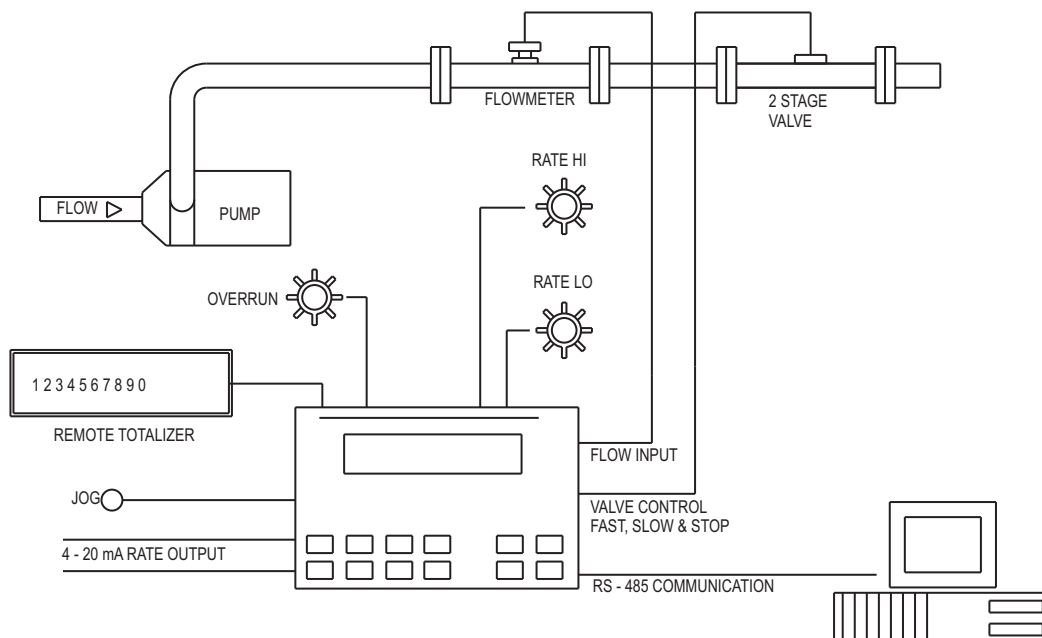

FIG. 4 - TYPICAL APPLICATION - BATCH / RATE CONTROL

INSTALLATION REQUIREMENTS

The velocity profile is reshaped by the cone sensor & hence there is no need for long upstream straight pipe lengths. Typically installation piping requirements are about 3 Diameter Upstream & 5 Diameters Downstream for all type of pipe fittings present upstream.

The **EUREKONE FLOWMETER** may be installed in either horizontal or vertical piping.

APPLICATIONS

The **EUREKONE FLOWMETER** finds application in the measurement of flow of Water, Steam, Air, Nitrogen, Hydrogen, Coke oven gas, Propane, Argon, Neon, Exhaust Gases & many more fluids.

SPECIFIC APPLICATIONS

- 1) Monitoring air / water / steam consumption.
- 2) Wet gas measurement.
- 3) Oil measurement.
- 4) Condensate measurement.
- 5) Measurement of liquid containing particles is also possible
- 6) Any media which is difficult to handle by other differential flow meter can be measured.

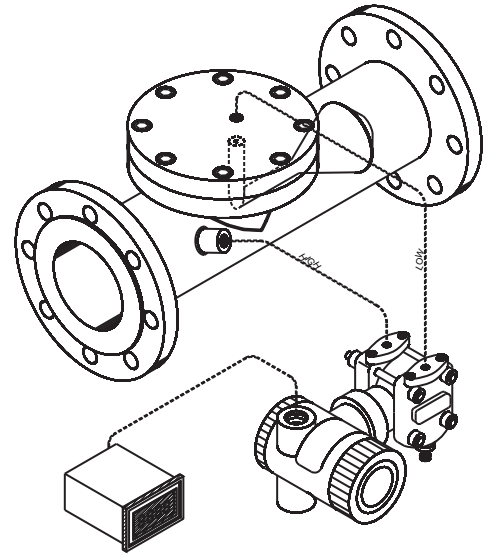

GENERAL SPECIFICATIONS	
ACCURACY	±1% of actual flow for EK-I to EK-XX & ±3% of actual flow for EK-20 to 40
REPEATABILITY	±0.5%
PRESSURE LOSS	Varies with Beta Ratio but usually very low
INSTALLATION	3 Pipe Diameters Upstream. 5 Pipe Diameters Downstream.
MATERIALS (STD.)	Carbon Steel, AISI316, AISI304
PRESSURE	20 Bar, Higher on Request
TEMPERATURE	100°C, Higher on Request
LINE SIZE	3/4" to 20"
END CONNECTIONS	Flanged as per ANSI B 16.5 or any other std.
RANGEABILITY	10:1 for EK-I to EK-XX

GENERAL SPECIFICATIONS CE MARKED EUREKONE FLOWMETER AS PER PED 2014/68/EU	
ACCURACY	±1% of actual flow(±2-3% of actual flow for 1" & 1.5"NB)
REPEATABILITY	±0.5%
PRESSURE LOSS	Varies with Beta Ratio
INSTALLATION	3 Pipe Diameters Upstream. 5 Pipe Diameters Downstream.
MATERIALS (STD.)	ASTM-A-351 grade CF-8M or CF-3M
PRESSURE	20 BAR
TEMPERATURE	300°C
END CONNECTIONS	Flanged as per DIN EN 1092-1 PN40, TYPE 21

Model No. (size)	Min. R ₀	Max. R ₀	Flow Ranges*
EK-20 (3/4"NB)	1.3E +04	8.5E +04	5 M3/HR MAX.
EK-25 (1"NB)	2E +03	8.5E +04	10 M3/HR MAX.
EK-40 (1.5"NB)	1.9E +03	1.8E +05	20 M3/HR MAX.
EK-I (2"NB)	1.93E +04	4.27E +05	2.5 - 19 M3/HR To 4.8 - 47 M3/HR
EK-II (3" NB)	4.4E +04	5.3E +05	8 - 45 M3/HR To 16 - 100 M3/HR
EK-III (4" NB)	2.1E +04	6.9E +05	4 - 80 M3/HR To 10 - 160 M3/HR
EK-IV (6" NB)	3.12E +04	8.56E +05	11- 155 M3/HR To 43 - 450 M3/HR

Model No.(Size)	Min. R ₀	Max. R ₀	Flow Ranges*
EK200 (8"NB)	1.89E+05	7.56E+05	300 M3/HR
EK250 (10"NB)	2.37E+05	9.51E+05	490 M3/HR
EK300 (12"NB)	2.85E+05	1.14E+06	700 M3/HR
EK350 (14"NB)	3.14E+05	1.25E+06	850 M3/HR
EK400 (16"NB)	3.62E+05	1.44E+06	1100 M3/HR
EK450 (18"NB)	4.09E+05	1.63E+06	1450 M3/HR
EK500 (20"NB)	4.57E+05	1.82E+06	1800 M3/HR

*Calculated for water at ambient temp., dp of 2500 mm WC and pressure 2 bar g

ACCESSORIES

- 1) Power Supply for DPT with digital Flow indicator with or without totaliser
- 2) Flow Computer with Pressure Transmitter & Temperature Transmitter for compensation.
- 3) Impulse Tubing
- 4) Manifold
- 5) Condensing Pots
- 6) D. P. Transmitter

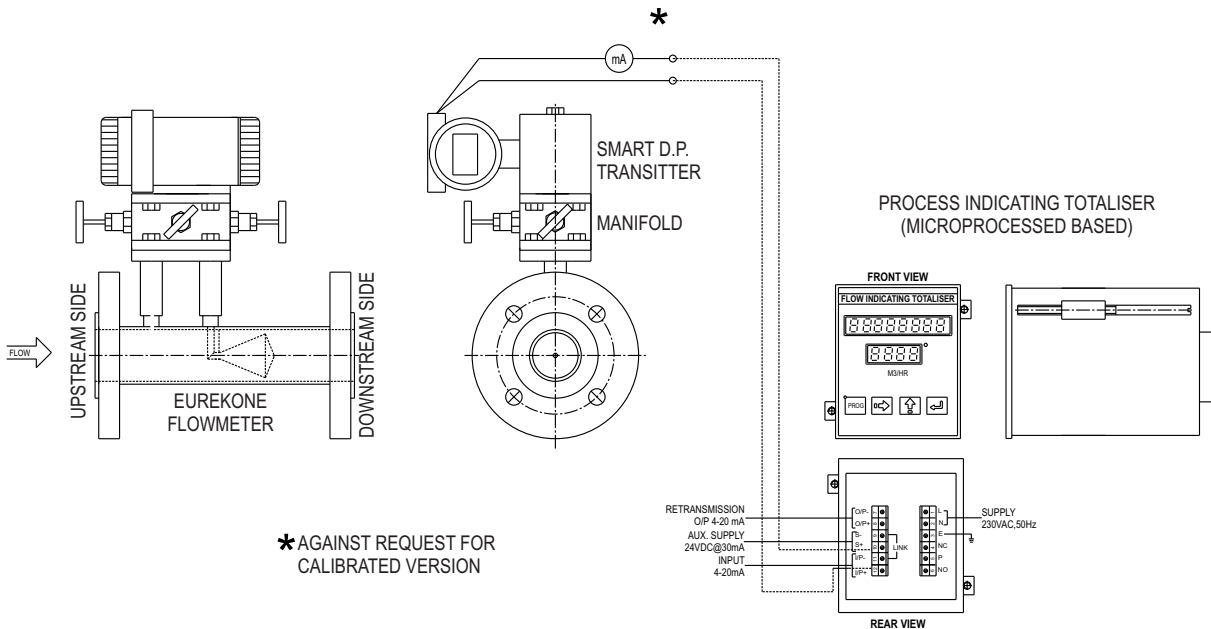

EUREKONE WITH DIRECT DPT MOUNTING

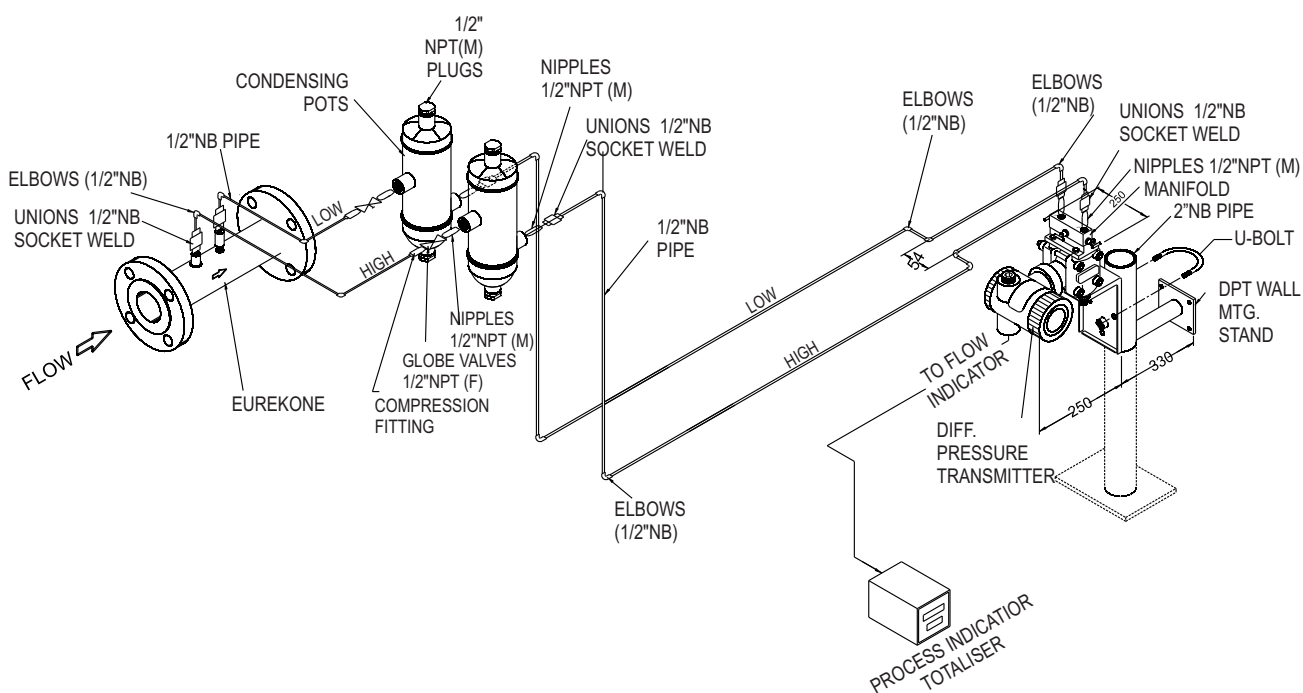

**TYPICAL INSTALLATION DRG. STEAM APPLICATION
(WITH OR WITHOUT IBR)**

EUREKONE FLOWMETER is most superior compared to other flowmeters. Following comparison proves the superiority of EUREKONE.

<p>EUREKONE FLOWMETER</p> <p>A) Low installation cost</p> <p>B) Same accuracy with dirty particles content fluids</p> <p>C) Reliable for any application</p> <p>D) Low pressure loss</p> <p>E) High turn down ratio</p> <p>F) Maintenance free</p>	<p>ORIFICE PLATE</p> <p>A) High installation cost due to very long straight pipe runs requirements.</p> <p>B) Subject to abrasion and loss of accuracy</p> <p>C) Not reliable for wet gas condensate measurement</p> <p>D) High pressure loss</p> <p>E) Low turn down 4:1</p> <p>F) Requires routine maintenance</p>
<p>EUREKONE FLOWMETER</p> <p>A) Low cost</p> <p>B) High accuracy</p> <p>C) Wide range of applications including high temp.</p> <p>D) Long term accuracy</p>	<p>ULTRASONIC</p> <p>A) Very high cost</p> <p>B) Accuracy not guaranteed</p> <p>C) Not suitable for high temp. fluids.</p> <p>D) Requires periodic calibration</p>
<p>EUREKONE FLOWMETER</p> <p>A) Low cost</p> <p>B) Low installation cost</p>	<p>VORTEX</p> <p>A) High cost</p> <p>B) High installation cost due to requirement of long straight runs.</p>

NOTE

EUREKONE FLOWMETER can be used for any medium, provided Reynolds number is within the limit specified.

SCOPE OF SUPPLY

Our standard scope of supply includes EUREKONE FLOWMETER +D.P. Transmitter of reputed make. Secondary instrumentation like flow indicator totalizer will be supplied against request. Power supply required for DPT - 24 VDC. O/P 4 to 20mA Two wire systems.

DATA REQUIRED FOR SIZING

FLUID, FLOW RANGE, OP. TEMP., OP. PRESSURE, DENSITY, VISCOSITY AT AN OP. TEMP.

* We reserve the right to modify the Design & Specifications without notice